

Puzz 3D®

The Golden Carousel

From the travelling circuses of the Middle Ages to today's huge theme parks, carousel have always drawn a crowd and excited both young and old. From the first equestrian tournaments with their rows of knights and sumptuous carriages, to the fairground carousels with wooden horses glittering with colour and light, everything was spectacle and dazzle. The carousel's origins can be traced back to a game inspired by combat training in the Middle Ages: ring piercing. In this competition, the rider had to pierce a small copper ring dangled from a pole or bracket with his sword or lance. This game probably provided the inspiration for the carousel with the wooden horses that we know today.



Caught between a time of tradition and the modern age, the golden age of country fairs occurred between 1880 and 1930, and coincided with the arrival of the industrial revolution at the beginning of the 20th century. Now, travelling shows offered more interesting and more elaborate presentations both in decorative arts and in fine art. Ride-type attractions of this period, which were now available to all social classes and all ages, were imaginative, original and aesthetic. Members of the travelling art community displayed the high quality of their workmanship in this golden age. Everyone, expert or not, could appreciate the exceptional work of these sculptors of animals. The real-life rendering of many of the menageries combined with the superb quality of the sculpting could reveal the smallest anatomical detail of a hoof and shoes, or the facial veins of the horse. French carousel horses were distinguishable by their quiet appearance, and their coats were often white. Harnesses were exactly like those used at the time of the golden age, such as a classic flat saddle and a saddle blanket covering part of the hind quarters. The rear legs were a little short and the heads a little large, resembling small trotting horses.

Music Please!

Whether it was a barrel organ played manually by wandering musicians, or one of the huge organs with more than a hundred keys, each carousel had its own instrument. There had to be music with a carousel, not only to announce its presence in the middle of a busy fairground but also to emphasize its circular motion.



ASSEMBLY INSTRUCTIONS FOR YOUR PUZZ-3D® ADVENTURE!

1 Remove and set aside waste pieces

Pieces with red dots are not to be used in your puzzle; just place them in a safe place, such as a plastic bag. Some very tiny (1/4 inch square) will need to be pushed out from the middle of puzzle pieces. Frequently, puzzle pieces are still attached to red-dot pieces and it's easy to miss them.

DO NOT THROW AWAY ANY RED-DOT PIECES UNTIL YOUR PUZZLE IS COMPLETED!



Various types of red-dot pieces

2 Examine the types of puzzle pieces

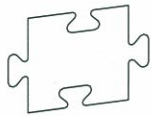

Jigsaw: These pieces have regular jigsaw cuts and are used in the middle of a wall or base. They are never used to create an edge or corner.

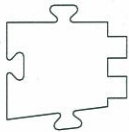

Square: These pieces have square cuts on one or more sides. They "dovetail" with pieces having the same type of edge to form an angle when they connect. These pieces create your puzzle's corners and are what make your Puzz-3D® three dimensional! A corner can be formed by connecting a base to a wall or a wall to another wall. See illustration.

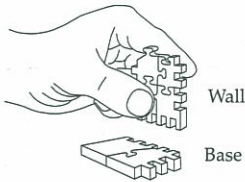

Wall

Base

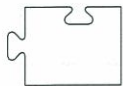

Straight edge



Curved edge

Edge: These pieces have one or two straight or curved edges. The outside edge of the base of your puzzle is made up of these, but they can also create an edge of another section, such as the top of a wall.

Decorative: The remainder of your pieces are decorative and are usually added at the end to complete your puzzle. An example would be the top of a tower.

3 Assemble the sections

Sort pieces according to color and design, then assemble them to form flat sections. When connecting pieces, be sure the artwork on the two pieces match perfectly. In most cases, a finished section will have its perimeter entirely made up of square cut pieces, as shown here. Some sections, however, may have one or more sides that are straight or curved.

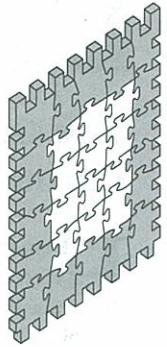

A completed section with square-cut pieces in gray

4 Think vertical!

Remember, your puzzle is not just a picture, but a dimensional model! The inside will be hollow. The vertical walls attach to the horizontal base wherever each side consists of square cut edges. The base will be flat and the walls will go UP!

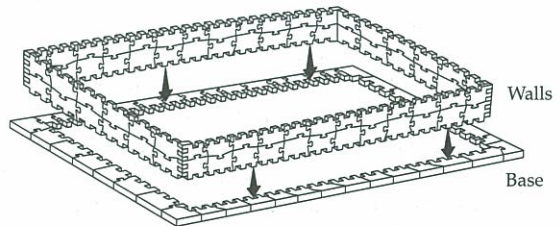

A sample of a base and walls

5 Helpful hints

Handling the puzzle pieces may cause static electricity which could make them cling to your clothing. Keep your puzzle away from infants and house pets. Animals love to chew the foam pieces and this may cause choking. Please note however that they are non-toxic. In order to preserve your puzzle, keep away from intense heat such as radiators and the sun. This may cause warping and color fading.

Puzz 3D

The Golden Carousel Le Carrousel Doré

This box contains:
Cette boîte comprend :

338 puzzle pieces
pièces de puzzle

+9 cardboard supports
+9 supports de carton

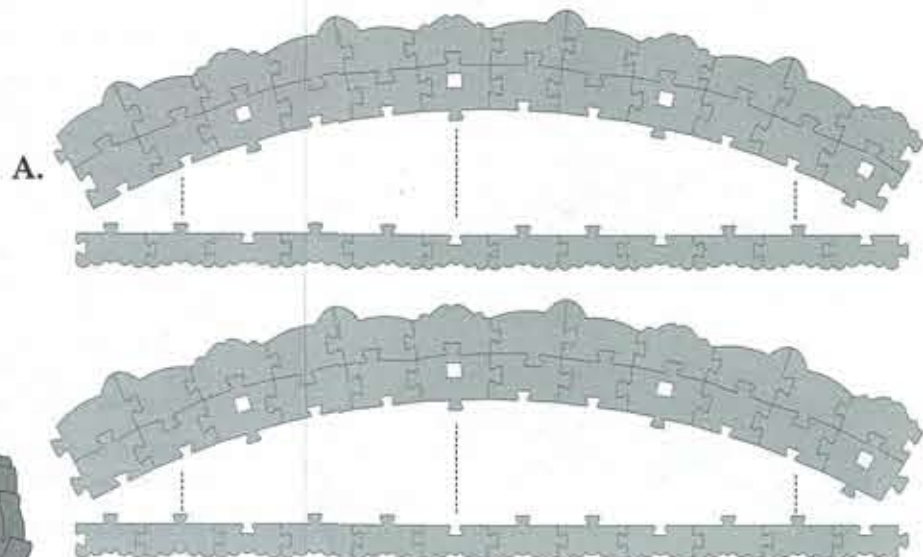
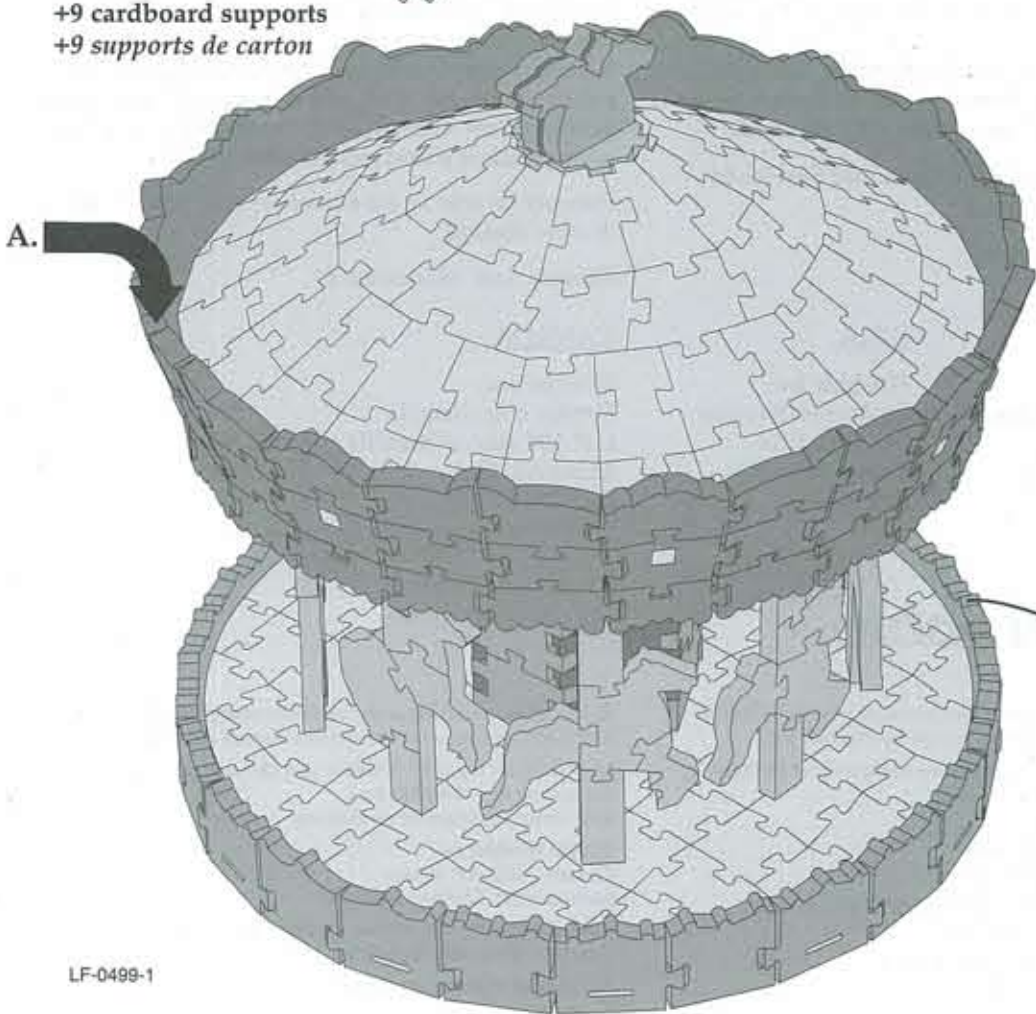

NOTE: BECAUSE THE ROOF IS CURVED
IN ITS STRUCTURE, THE ARTWORK OF THE
PUZZLE PIECES MAY NOT APPEAR
TO MATCH PERFECTLY.

NOTE : LE CHAPITEAU AYANT UNE FORME
COURBE, IL SE PEUT QUE LA CONTINUITÉ DE
L'ILLUSTRATION NE SOIT PAS PARFAITEMENT
LINÉAIRE D'UNE PIÈCE DE PUZZLE À L'AUTRE.

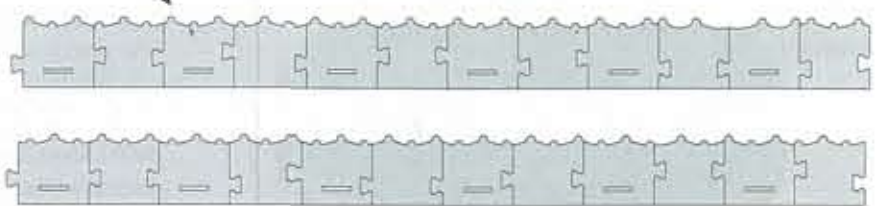

Cardboard Support Assembly. Assemblage des supports en carton.

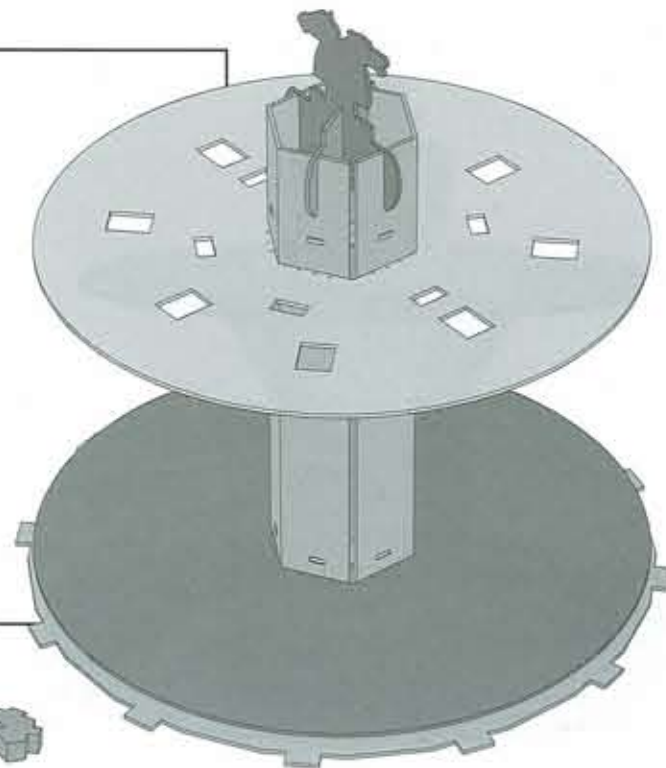
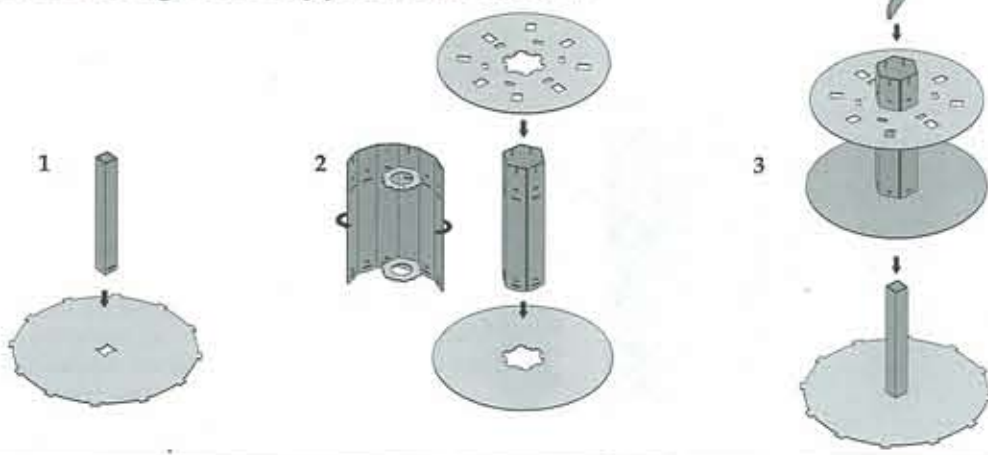

Make the carousel
go 'round by turning
this section.

Faites pivoter votre carrousel
en saisissant cette section.

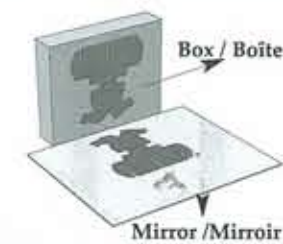
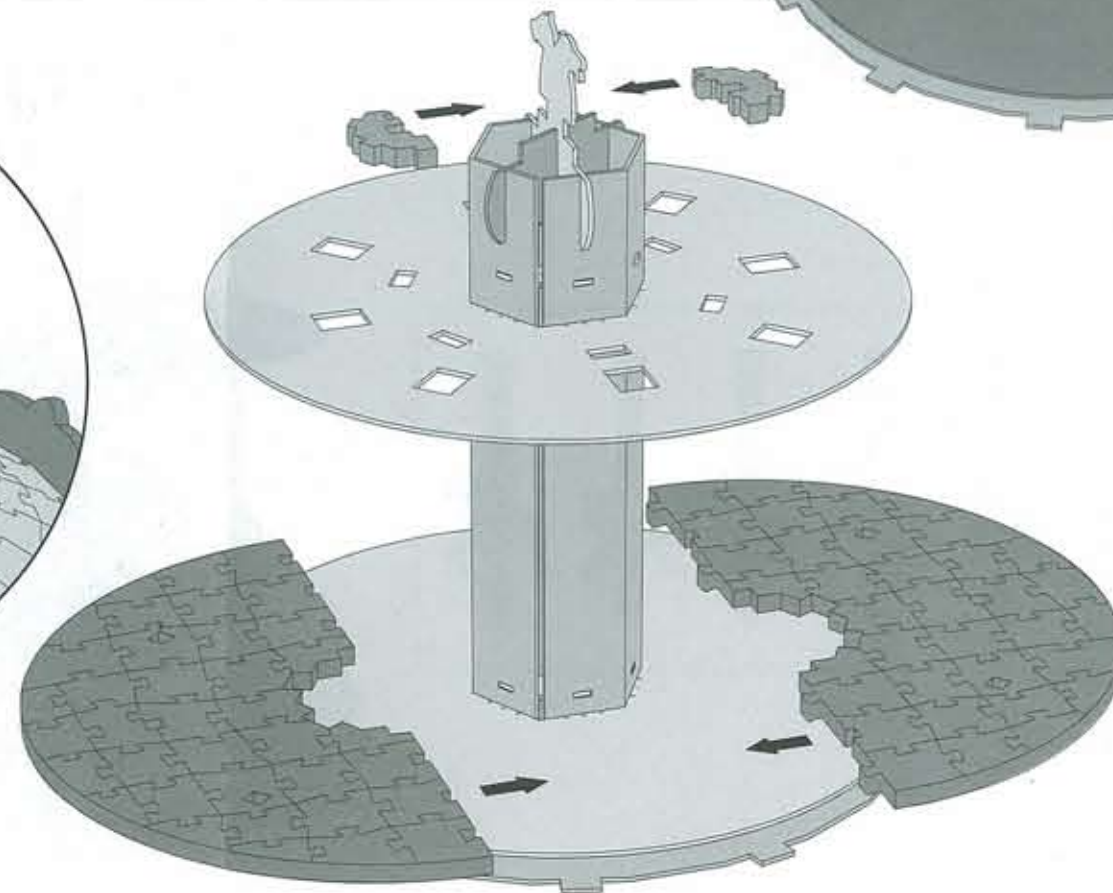
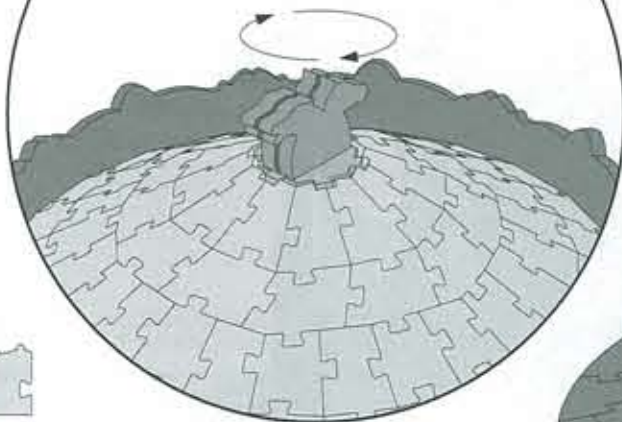

ERRATUM:
Unfortunately, the pictures on
the back of the box have been
reversed. Use a mirror to see
them properly.

Les photos à l'arrière de la boîte
ont été malencontreusement
inversées. Utilisez un miroir
pour les voir convenablement.

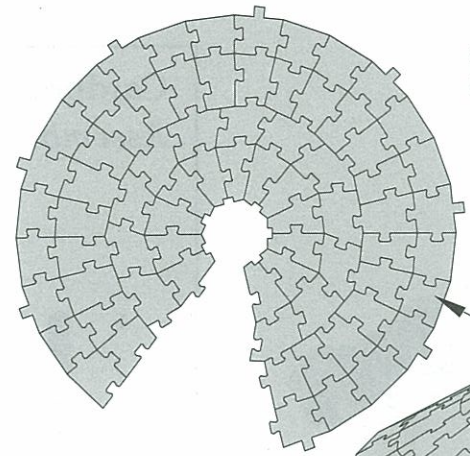
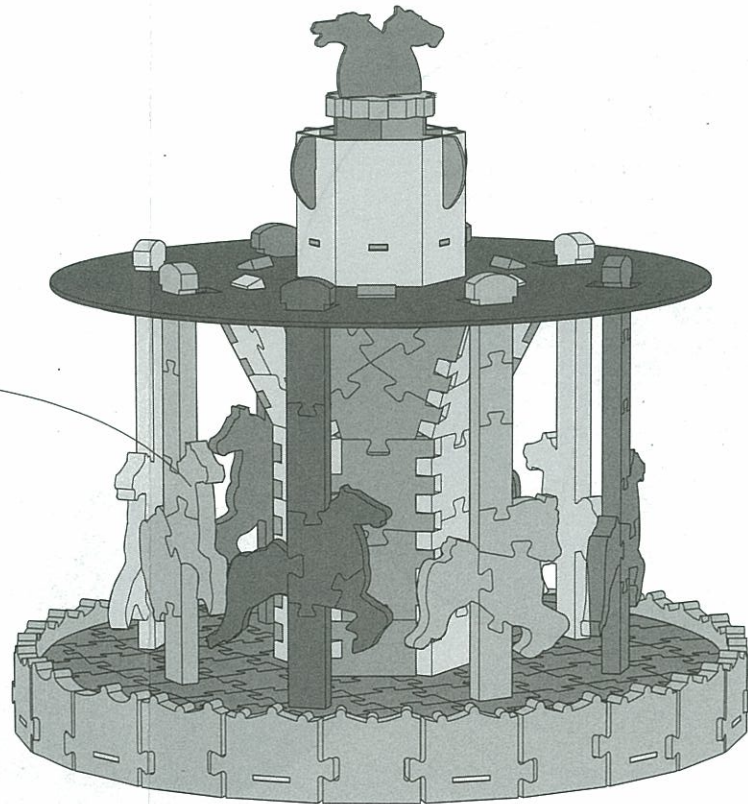
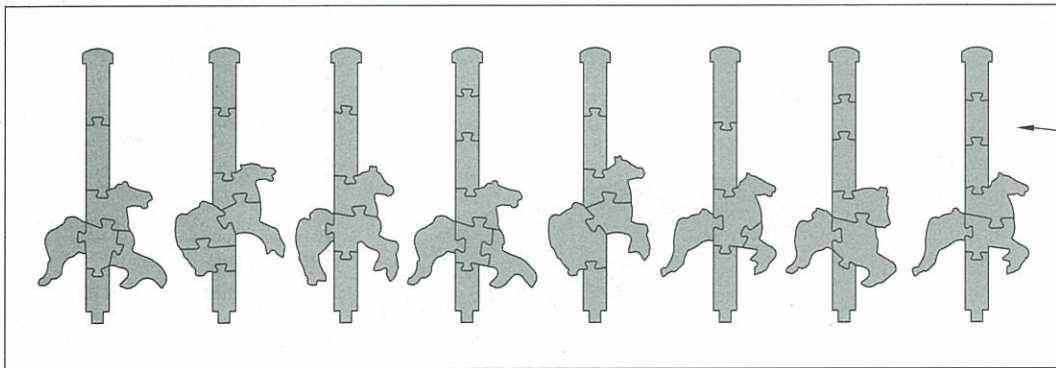
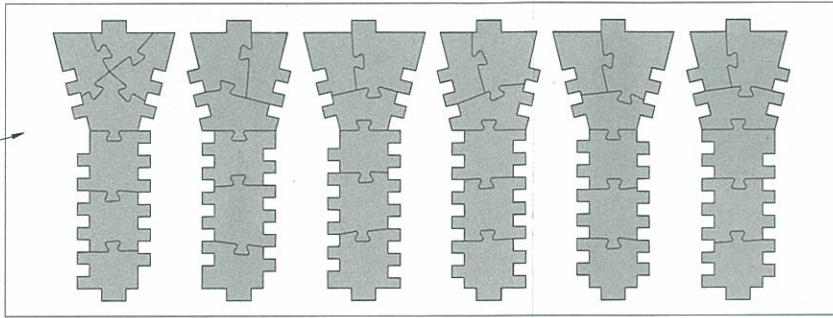
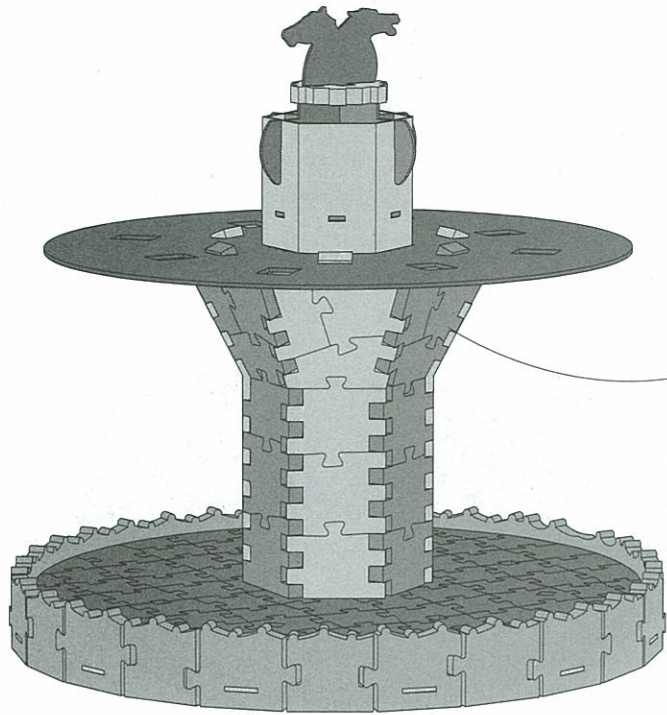

Spread out roof
Chapiteau déployé

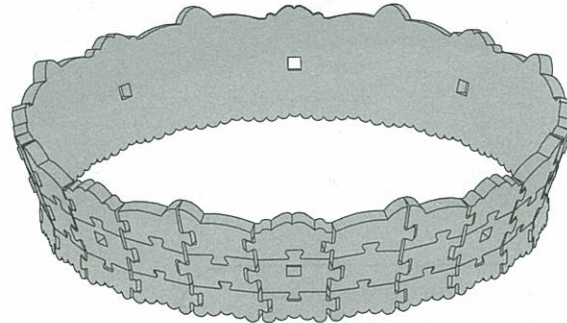
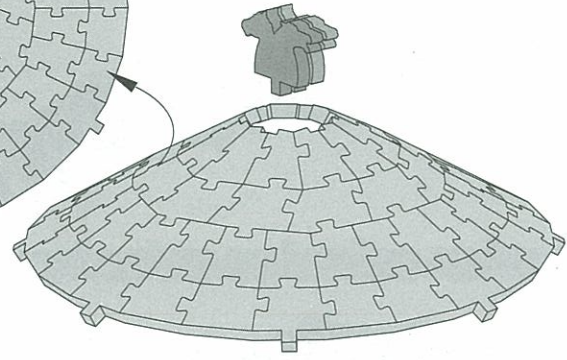

Exploded View
Vue Explosé

